

WK SERIES

2-wire TRANSMITTER



**Monitors or signal converters are unnecessary.
Electric current output makes long wiring possible.**

Direct connection to control instruments.

The ideal system for monitoring small compressor vibrations.



**Sales
SHINKAWA Electric Co., Ltd.**

3rd Fl. Shin-kojimachi Bldg.3-3 Kojimachi 4-chome, Chiyoda-ku, Tokyo 102-083, Japan
Tel : 81-3-3263-4417 Fax : 81-3-3262-2171 E-mail : st-mkt@shinkawa.co.jp
Web : <http://www.shinkawaelectric.com/en/>

**Manufacturing
SHINKAWA Sensor Technology, Inc.**

4-22 Yoshikawa-kogyodanchi, Higashihiroshima 739-0153, Japan
Tel : 81-82-429-1118 Fax : 81-82-429-0804 E-mail : info@sst.shinkawa.co.jp
Web : <http://www.shinkawa.co.jp/sst/>

* Specifications, outline drawings and other written information can be changed without notice.
* When exporting Shinkawa products, permission may be required for export or service transactions, pursuant to the provision of the Foreign Exchange and Foreign Trade Act.
When re-exporting Shinkawa products, permission may be required from the US Department of Commerce, pursuant to the provision of the Export Administration Regulation (EAR).
Please contact our service representative for further information.

* All company and product names in this brochure are trademarks or registered trademarks.

Published in Jan.2015

SIMPLE WIRING - 2-WIRE TRANSMITTER

The WK series transmitter is an eddy-current type transmitter that incorporates vibration converter features, supplying the power and transmitting the signal with a 2-wire current loop. The WK system reduces equipment and wiring costs. Two kinds of transmitters are available - the WK-142K for shaft vibration, and the WK-142T for thrust position.



Monitors or vibration converters are unnecessary. Electric current output makes long wiring possible. Direct connection to control instruments. The ideal system for monitoring small compressor vibrations.

Example of SYSTEM CONFIGURATION

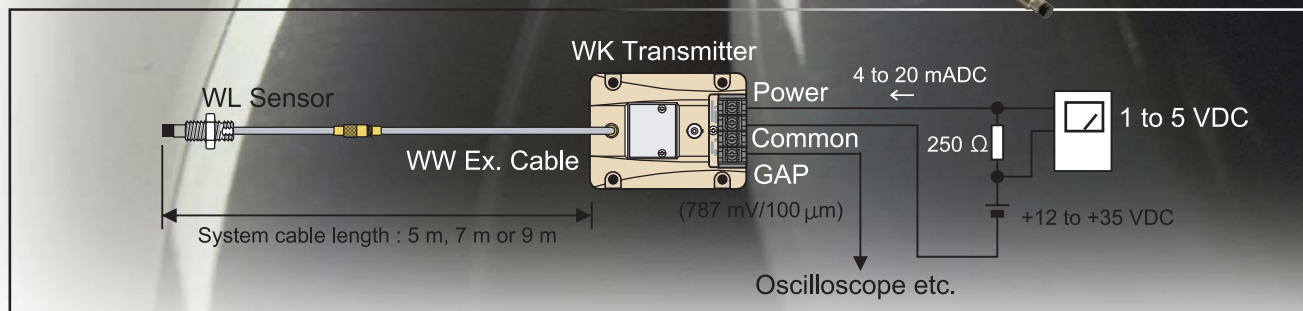

Outline Drawing

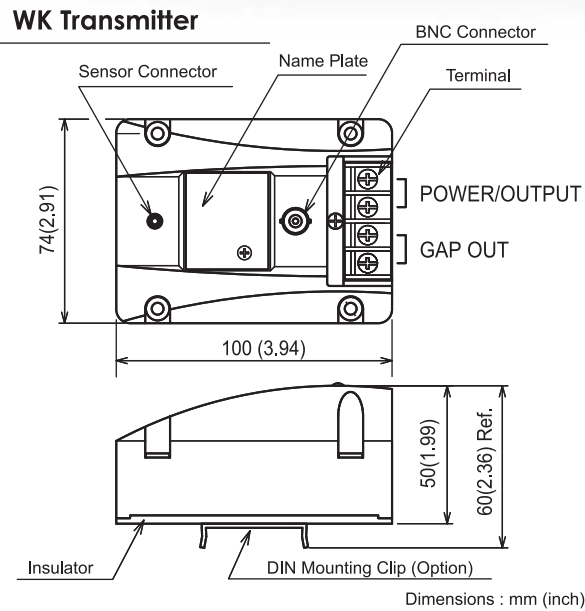

Specifications

	WK-142K	WK-142T
Current Output		
4 to 20mA Output Range	0 to 100 μ m pk-pk, 0 to 125 μ m pk-pk, 0 to 200 μ m pk-pk, 0 to 250 μ m pk-pk, 0 to 400 μ m pk-pk	-0.6 to 0 to +0.6 mm, -0.635 to 0 to +0.635 mm
4 to 20mA Output Conversion Accuracy	$\pm 1.5\%$ of full scale range (from test signal input pin to current output)	$\pm 1.0\%$ of full scale range (from test signal input pin to current output)
Max. Load Resistance	43.5 \times (Vps-12) Ω (Vps=Power supply voltage)	
Calibration Material	JIS SCM440 flat (AISI 4140 equivalent)	
Linear Range*	1.4 mm (Gap : 0.3 to 1.7 mm)	
Scale Factor*	7.87 mV/ μ m	
Scale Factor Error*	5 m, 7 m system : 7.87 mV/ μ m $\pm 6.5\%$ typ. (including interchangeability errors) 9m system : 7.87 mV/ μ m $\pm 10\%$ typ. (including interchangeability errors) Step : 200 μ m, Target : 30 mm dia.	
Output Impedance*	10 k Ω (it is calibrated load impedance at 10 M Ω)	
Frequency Response*	5 Hz to 6,000 Hz (+0 dB, -3 dB) at 900 μ m Gap	
Operating Temperature Range	Transmitter : 0 to 70°C Sensor & Extension cable : -34 to +177°C (Connector : Max.125°C)	
Relative Humidity	95% RH (non-condensing)	
Power Supply Voltage	12 to 35 VDC	
System Cable Length	5 m, 7 m or 9 m	5 m, 7 m

* The above specifications apply at 25°C with 24 VDC power supply and SCM440 (AISI 4140 equivalent) steel flat target.

Model Code

For Shaft Vibration

WK-142K □ - □ /NB □ /DNC /CEM

System Cable Length	Output Range	Non-incendive	With DIN Mounting Clips	CE Marking
1	5 m	1 0 to 100 μ m pk-pk	1	CSA : Class I Div.2 Gr. A,B,C,D ATEX : Ex nA II T6
2	7 m	2 0 to 125 μ m pk-pk	8	KTL : Ex nA II T4
		3 0 to 200 μ m pk-pk		
		4 0 to 250 μ m pk-pk		
		5 0 to 400 μ m pk-pk		

For Thrust Position

WK-142T □ - □ /NB1 /DNC /CEM

System Cable Length	Output Range	Non-incendive	With DIN Mounting Clips	CE Marking
1	5m	1 -0.6 to 0 to +0.6 mm	1	CSA : Class I Div.2 Gr. A,B,C,D ATEX : Ex nA II T4
2	7m	2 -0.635 to 0 to +0.635 mm (-25 to 0 to +25 mils)		

Outline Drawing and Model Code

WL Sensor

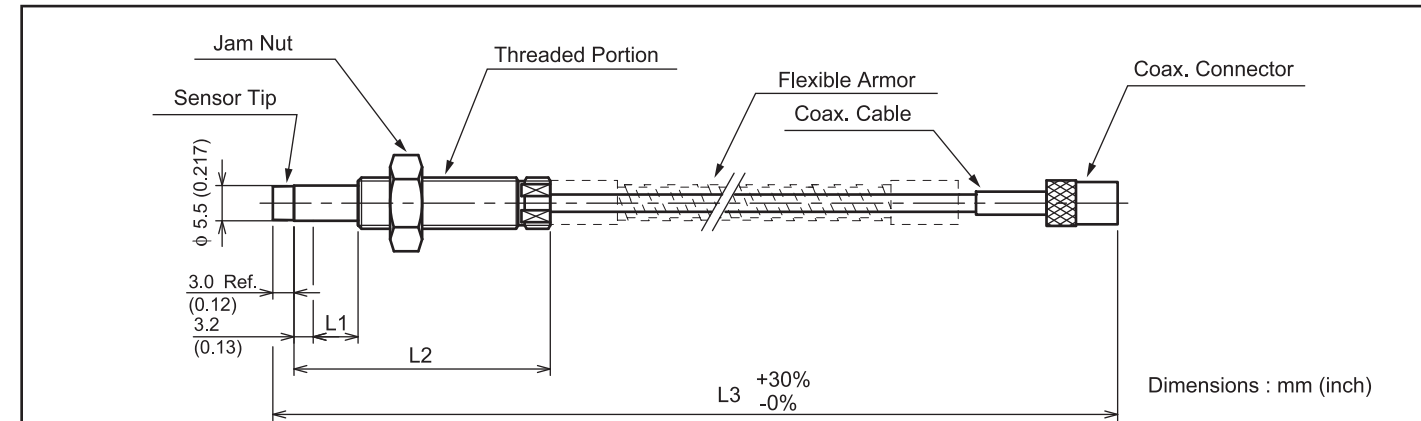

WL-142K05 □ - □ □ □ □ □ □ □ □ /NB □

	Armor	Threaded Size	Unthreaded length* (L1)	Case length* (L2)	Cable length (L3)	Non-incendive
A	With (Without Fluoro resin coating)	M1	M8 x 1	10 mm step, 0 to 230 mm e.g.) 06 = 60 mm L1 \leq L2 - 20 mm	10 mm step, 20 to 250mm e.g.) 25 = 250 mm	1 0.5 m
		M2	M10 x 1			2 1.0 m
		U1	1/4-28 UNF-2A	0.1 inch step, 0 to 9.2 inch e.g.) 04 = 0.4 inch L1 \leq L2 - 0.7 inch	0.1 inch step, 0.8 to 9.9 inch e.g.) 35 = 3.5 inch	3 5.0 m
T	With (With Fluoro resin coating)	U2	3/8-24 UNF-2A			4 7.0 m
						5 9.0 m

* inch for UNF-2A thread mm for M thread

WW Extension Cable

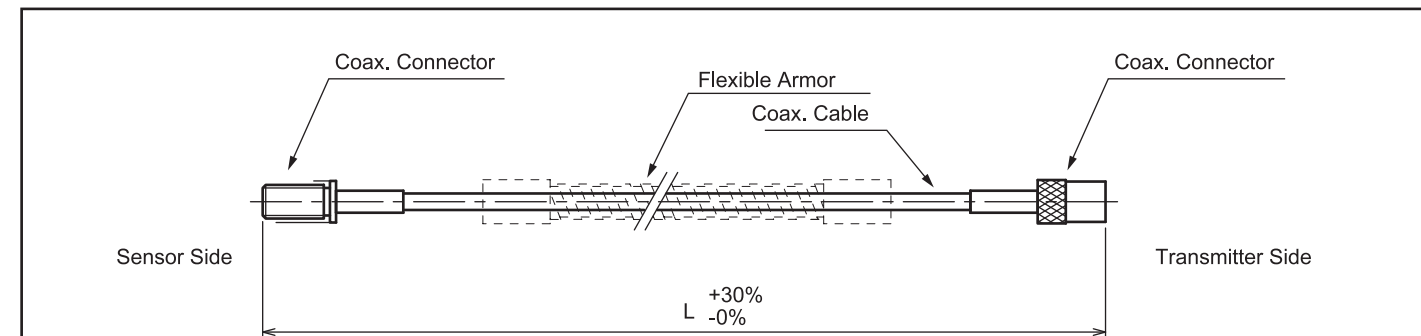

WW-142K □ - □ /NB □

	Armor	Extension Cable length	Non-incendive
A	With (Without Fluoro resin coating)	1 4.0 m	1 CSA : Class I Div.2 Gr. A,B,C,D ATEX : Ex nA II T6
T	With (With Fluoro resin coating)	2 4.5 m	8 KTL : Ex nA II T4
L	Without	3 6.0 m	
		4 6.5 m	